

CP08/M DISTRIBUTION PANEL TECHNICAL MANUAL



3545 Harbor Boulevard
Costa Mesa, California 92626
(714) 662-5600 TWX 910-595-2521

CP0851001-00 Rev A
March, 1987

WARNING

This equipment generates, uses and can radiate radio frequency energy, and if not installed and used in accordance with the technical manual, may cause interference to radio communications. It has been tested and found to comply with the limits for a Class A computing device pursuant to Subpart J of Part 15 of Federal Communications Commission (FCC) Rules, which are designed to provide reasonable protection against such interference when operating in a commercial environment. Operation of this equipment in a residential area is likely to cause interference in which case the user at his own expense will be required to take whatever measures may be required to correct the interference.

Copyright (c) 1986 Emulex Corporation

The information in this manual is for information purposes and is subject to change without notice.

Emulex Corporation assumes no responsibility for any errors which may appear in the manual.

Printed in U.S.A.

TABLE OF CONTENTS

ONE INTRODUCTION

1.1	OVERVIEW	1-1
1.2	GENERAL DESCRIPTION	1-1
1.2.1	Emulex Part Numbers	1-2
1.3	GENERAL SPECIFICATIONS	1-3
1.4	INTERFACE SPECIFICATIONS	1-5
1.5	WRAP-AROUND CONNECTOR	1-6

TWO PRELIMINARY CONSIDERATIONS

2.1	OVERVIEW	2-1
2.2	MAINTAINING FCC CLASS A COMPLIANCE	2-1
2.3	THREE-POSITION SWITCH	2-1
2.4	JUMPER OPTIONS	2-2
2.5	RS-232-C CABLE LENGTHS	2-3

THREE INSTALLATION

3.1	OVERVIEW	3-1
3.2	MicroVAX AND MicroPDP-11 MOUNTING	3-1
3.2.1	Mounting a Second CP08/M	3-3
3.3	RACK-MOUNTING (SAME CABINET)	3-4
3.4	ATTACHING EXTERNAL DEVICES TO THE CP08/M	3-6
3.4.1	Terminals and Printers	3-6
3.4.2	Modems	3-6
3.4.3	Null-Modem Operation	3-6

EMULEX PRODUCT WARRANTY

DISTRIBUTION PANEL WARRANTY: Emulex warrants for a period of twelve (12) months from the date of shipment that each Emulex controller product supplied shall be free from defects in material and workmanship.

CABLE WARRANTY: All Emulex provided cables are warranted for ninety (90) days from the time of shipment.

The above warranties shall not apply to expendable components such as fuses, bulbs, and the like, nor to connectors, adaptors, and other items not a part of the basic product. Emulex shall have no obligation to make repairs or to cause replacement required through normal wear and tear or necessitated in whole or in part by catastrophe, fault or negligence of the user, improper or unauthorized use of the product, or use of the product in a manner for which it was not designed, or by causes external to the product, such as but not limited to, power failure or air conditioning. Emulex's sole obligation hereunder shall be to repair or replace any defective product, and, unless otherwise stated, pay return transportation cost for such replacement. Purchaser shall provide labor for removal of the defective product, shipping charges for return to Emulex and installation of its replacement.

THE EXPRESSED WARRANTIES SET FORTH IN THIS AGREEMENT ARE IN LIEU OF ALL OTHER WARRANTIES, EXPRESSED OR IMPLIED, INCLUDING WITHOUT LIMITATION ANY WARRANTIES OF MERCHANTABILITY OR FITNESS FOR A PARTICULAR PURPOSE, AND ALL OTHER WARRANTIES ARE HEREBY DISCLAIMED AND EXCLUDED BY EMULEX. THE STATED EXPRESS WARRANTIES ARE IN LIEU OF ALL OBLIGATIONS OR LIABILITIES ON THE PART OF EMULEX FOR DAMAGES, INCLUDING BUT NOT LIMITED TO SPECIAL, INDIRECT, OR CONSEQUENTIAL DAMAGES ARISING OUT OF OR IN CONNECTION WITH THE USE OR PERFORMANCE OF THE PRODUCT.

RETURNED MATERIAL: Warranty claims must be received by Emulex within the applicable warranty period. A replaced product, or part thereof, shall become the property of Emulex and shall be returned to Emulex at Purchaser's expense. All returned material must be accompanied by a RETURN MATERIALS AUTHORIZATION (RMA) number assigned by Emulex.

1.1 Overview

This manual contains installation and application information for the CP08/M Distribution Panel. It needs to be used only for setup, installation, and cabling of the distribution panel itself. Setup and installation instructions for any other components in your subsystem are included in the controller technical manual that you received with the communications subsystem.

The contents of this manual are as follows:

- **Section 1 (Introduction).** This section contains an overview of the CP08/M Distribution Panel and CP08/M specifications.
- **Section 2 (Preliminary Considerations).** This section contains information necessary to plan the installation.
- **Section 3 (Installation).** This section describes how to physically install the distribution panel.

1.2 General Description

The CP08/M is an 8-port distribution panel for use with Emulex communications controllers. Each port is RS-232-C compatible and supports six modem control signals.

The CP08/M is designed for use with DEC's MicroPDP-11 and MicroVAX computers and mounts directly in the patch panel of either a MicroPDP-11 or MicroVAX. With a special mounting adapter and cables, it can also be mounted in a standard 19-inch RETMA equipment rack.

The CP08/M can be used with the Emulex products shown in Table 1-1.

Table 1-1. Emulex Products Used With the CP08/M

Product Name	Part Number
CS08/E1	CS0810201-00

1.2.1 Emulex Part Numbers

The Emulex part number for the CP08/M Distribution Panel is shown in Table 1-2. Part numbers for cables and other options are given in Table 1-3.

Table 1-2. CP08/M Part Numbers

Distribution Panel	Part Number
CP08/M	CP0810201-00

Table 1-3. Cables and Mounting Hardware

Item	Description	Part Number	Comment
1	64-Wire Ribbon Cable (connects controller to CP08/M)	CP0911201-01 CP0911201-02 CP0911201-03	1.5 foot 4 foot 8 foot
2	Rack-Mount Chassis	CU2213002	Required if CP08/M is rack-mounted
3	CP08/M Rack-Mount Adapter	CP0920602-00	Required if CP08/M is rack mounted.
4	Wraparound Connector	CU2210202	For diagnostic use
5	Staggered Loopback Cable	CU0411202	For diagnostic use

1.3 General Specifications

The CP08/M Distribution Panel consists of a mechanical assembly that contains eight 25-pin connectors. The eight channels on the CP08/M are numbered sequentially from 0 through 7 and are silkscreened on the faceplate of the panel. A modem control board attached to the rear of the unit controls the modem signals.

Figure 1-1 is a photograph of the CP08/M with a CS08/E1 controller. Figure 1-2 shows the physical dimensions of the CP08/M. Table 1-4 lists specifications for the CP08/M.

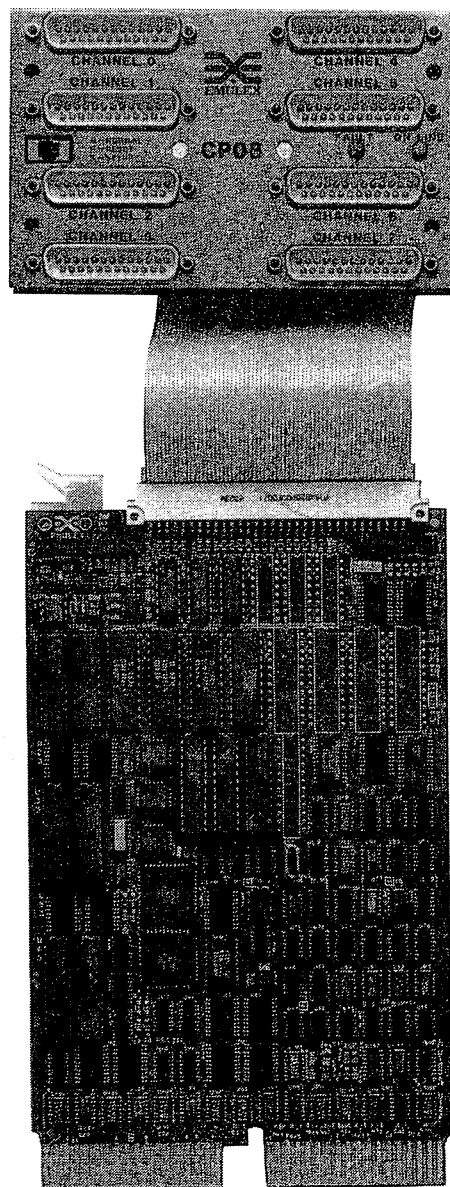

CP0801-1236

Figure 1-1. CP08/M Distribution Panel with CS08/E1 Controller

Table 1-4. CP08/M Distribution Panel Specifications

Parameter	Description
Connectors	25-pin male subminiature D-type RS-232-C compatible (electrically)
Operating Temperature	10°C (50°F) to 40°C (104°F) Maximum temperature is reduced 1.8°C per 1000 meters altitude (1°F per 1000 feet)
Relative Humidity	10 percent to 90 percent with a maximum wet bulb of 28°C (82°F) and minimum dewpoint of 2°C (3.6°F)
Dimensions	3.3 inches x 5.3 inches x 1.75 inches
Shipping Weight	2 pounds

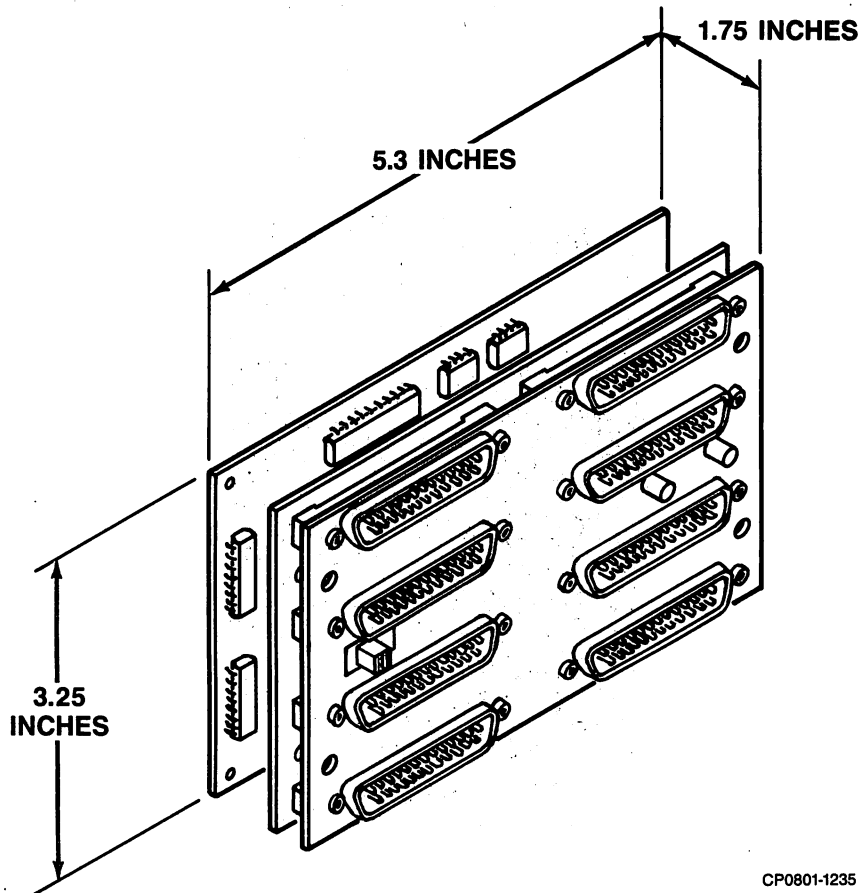

CP0801-1235

Figure 1-2. CP08/M Distribution Panel Dimensions

1.4 Interface Specifications

Electrical signal levels conform to EIA RS-232-C specifications. Modem control signals are available on all eight ports. Table 1-5 lists RS-232-C interface specifications for the CP08/M; Table 1-6 lists the pin/signal assignments for the CP08/M.

Table 1-5. CP08/M Interface Specifications

Parameter	Specification
Configuration	Data Terminal Equipment (DTE)
Transmission Mode	Half-duplex, full-Duplex
Transmission Speeds	0 to 38,400 bits per second
Modem Control Signals	CTS, RTS, DSR, DTR, Ring, DCD
Modems Supported Bell Compatible CCITT	103, 113, 212 V.22

Table 1-6. CP08/M Pin/Signal Assignments

Pin #	Function
1	Chassis Ground
2	Transmit Data
3	Receive Data
4	Request To Send
5	Clear To Send
6	Data Set Ready
7	Signal Ground
8	Carrier Detect
20	Data Terminal Ready
22	Ring

1.5 Wrap-Around Connectors

Some diagnostic tests require either a special wrap-around connector or a staggered loopback cable. Figure 1-3 shows the wraparound connector for the CP08/M. Figure 1-4 shows the staggered loopback cable.

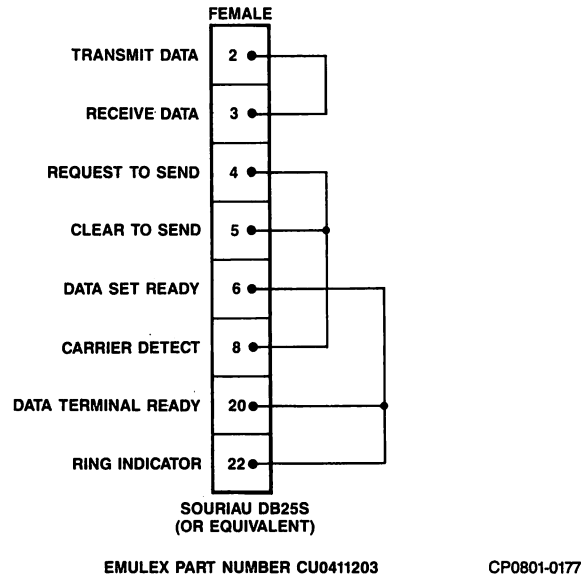

Figure 1-3. CP08/M Wraparound Connector

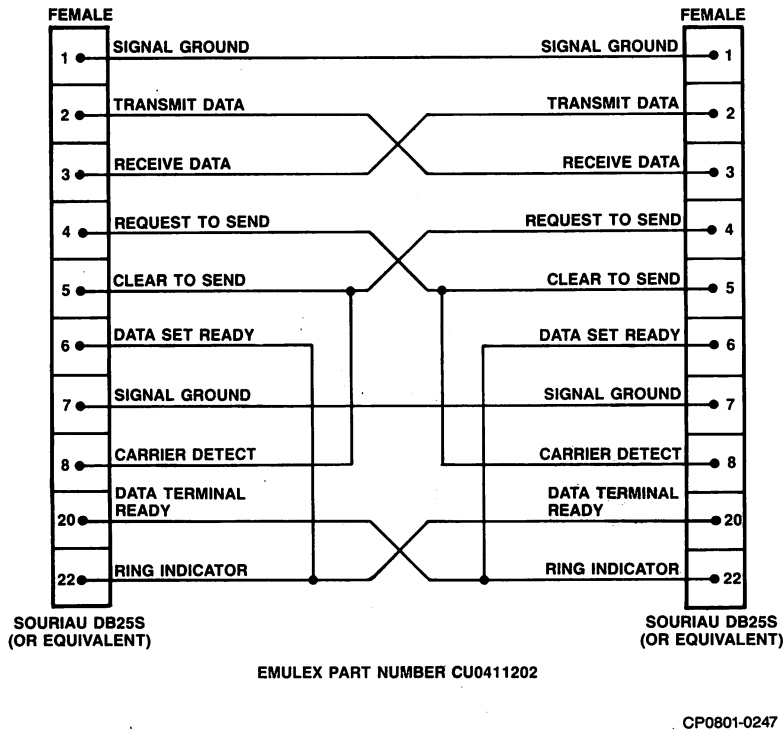

Figure 1-4. CP08/M Staggered Loopback Cable

2.1 Overview

This section describes some items that need to be considered before you configure and set up your communications subsystem.

2.2 Maintaining FCC Class A Compliance

The CP08/M Distribution Panel has been tested with DEC computers that comply with FCC Class A limits for radiated and conducted interference. The CP08/M is FCC compliant and is designed to be installed in the same cabinet as the controller, as described in Section 3 of this manual. The CP08/M must be installed as described in Section 3 in order to maintain FCC Class A compliance.

2.3 Three-Position Switch

The functions of the switch on the panel front are:

- NORM (Normal)** Activates all ports for normal operation.
- R (Reset)** Used to reset the panel. Most frequently used in conjunction with the Setup position for fault isolation procedures. See the Troubleshooting section of the controller technical manual.
- SETUP (Setup)** Used to configure the subsystem or to perform fault isolation procedures. See the Choosing Options section of the controller technical manual for configuration process information. See the Troubleshooting section of the controller technical manual for fault isolation procedures.

2.4 Jumper Options

The CP08/M contains two sets of jumpers that control grounding options. You must remove the modem control board from the rear of the panel to access the jumpers.

Figure 2-1 shows the location of the jumpers on the rear of the CP08/M. Both jumper pairs are connected in etch as shipped from the factory. You have the following options:

- If both etches are left in, signal ground for each channel is connected directly to chassis ground.
- If jumper E-B is cut, signal ground passes through a 100 ohm resistor before it grounds to the chassis.
- If both jumpers E-B and D-A are cut, signal ground is isolated completely from chassis ground. This option is recommended if you have a separate ground strap between the CP08/M and the external devices.

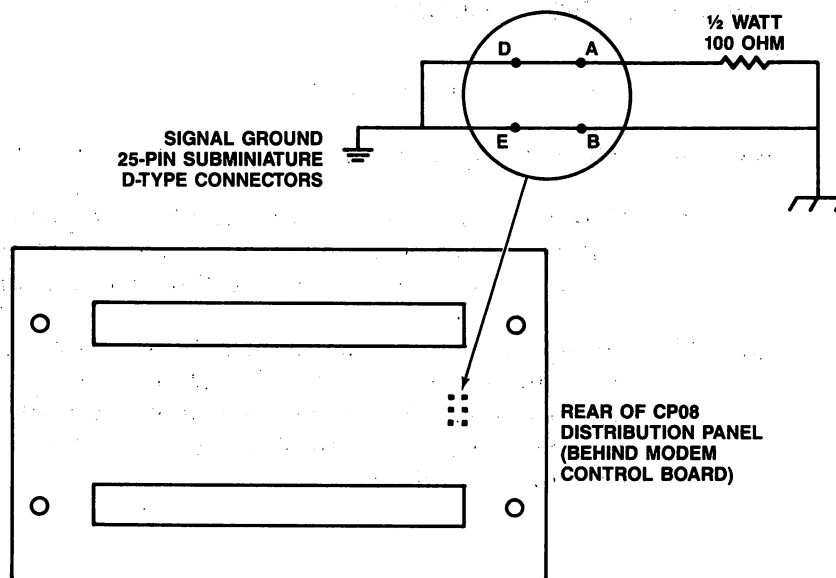

CP0801-1237

Figure 2-1. CP08/M Grounding Options

2.5 RS-232-C Cable Lengths

The EIA RS-232-C interface standard guarantees error-free transmission over cables no longer than 50 feet. Because the line drivers are on the controller module, this length includes the cable between the controller and the CP08/M. **Emulex does not guarantee operation over cable lengths greater than 50 feet in any circumstances.** However, satisfactory performance over cables several thousand feet in length can be obtained, depending on the speed of data transmission required and the environment in which the cable is placed.

NOTE

The ground potential difference between the controller and terminal must not exceed 2 volts. This requirement generally limits operation without modems to a single building served by one AC power service.

Table 2-1 is a guide to the practical application of RS-232-C cable lengths.

Table 2-1. RS-232-C Cable Lengths

Baud	Shielded ¹ (in feet)	Unshielded ² (in feet)
110	5000	3000
300	5000	3000
1200	3000	3000
2400	1000	500
4800	1000	250
9600	250	250

¹ Cable is two 22 AWG twisted pairs shielded in Belden 8777 (three pairs). Shields tied to ground.
² Cable is 22 AWG 4-conductor (quad) inside station wire.

3.1 Overview

This section describes how to mount and cable the CP08/M Distribution Panel.

Note that installation and cabling differ from CPU to CPU. There are two basic types of cabling:

- MicroVAX and MicroPDP-11.
- Rack-mounted computers (such as the LSI-11/23). The CPU and the distribution panel must be in the same equipment rack.

These two types of installation are described below. Read only the section that applies to your system.

3.2 MicroVAX and MicroPDP-11 Mounting

The CP08/M Distribution Panel is designed to mount in the patch panel of a MicroPDP-11 or MicroVAX. The following steps explain how to mount the CP08/M:

1. The patch panel on the rear of the CPU cabinet should already be removed. If it is not, remove the captive screws that hold the patch panel assembly to the rear of the MicroVAX or MicroPDP-11. Lift the panel slightly and pull it out, leaving the cables connected.

On a BA123 cabinet (World Box), the patch panel does not need to be removed.

2. Using a Phillips-head screwdriver, remove the blank panels labeled C and D. See Figure 3-1. On the opposite side of the patch panel, remove the screw that holds the divider between the panels in place.

On a BA123 cabinet, you may use any of the panel cutouts. The center divider does not need to be removed.

3. Position the CP08/M Distribution Panel in the aperture where the blank panels were located, by placing the face of the CP08/M against the back of the patch panel. The subminiature D-type connectors should extend through the aperture. Figure 3-2 illustrates the mounting of the CP08/M into the patch panel assembly.
4. Insert the screws provided with the distribution panel through the four clearance holes into the self-clinching fasteners on the front of the panel.

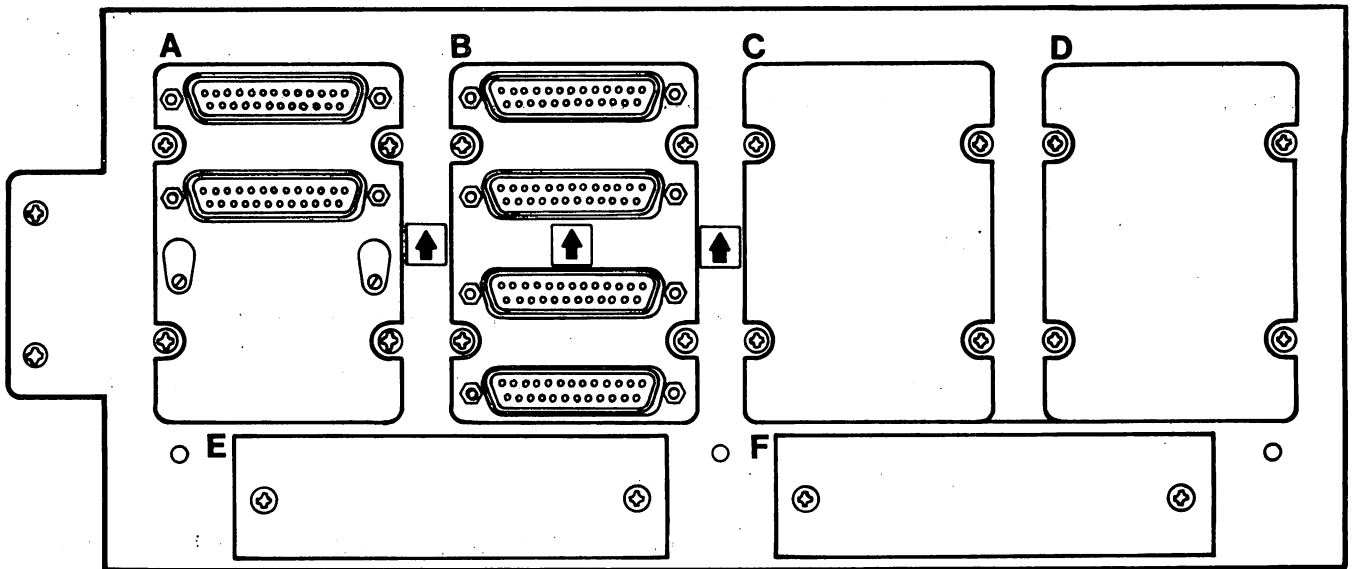

CP0801-0137

Figure 3-1. MicroVAX or MicroPDP-11 Patch Panel Assembly

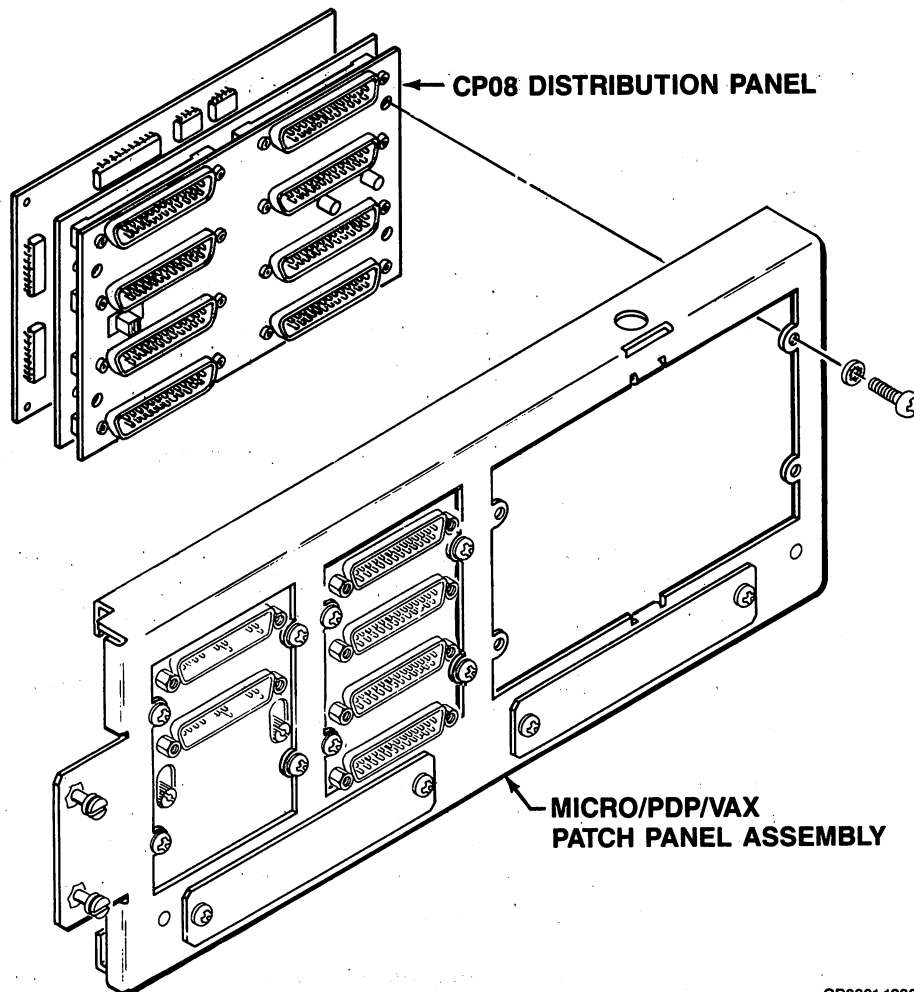

CP0801-1238

Figure 3-2. Mounting the CP08/M Distribution Panel

5. Attach one end of the 64-pin flat ribbon cable to the **top** connector on the CP08/M (labeled J1) and the other end to the connector on the edge of the CC09 controller (also labeled J1).
6. Re-install the patch panel in the rear of the CPU cabinet.
7. Installation of the distribution panel is now complete. Turn to section 3.4 for instructions on cabling external devices to the distribution panel (terminals, printers, etc.).

3.2.1 Mounting A CP08/M in A World Box

The CP08/M may be mounted in any cutout in a BA123 (World Box) cabinet. The center divider does not interfere with mounting the panel.

Figure 3-3 illustrates how to mount the CP08/M in a World Box cabinet.

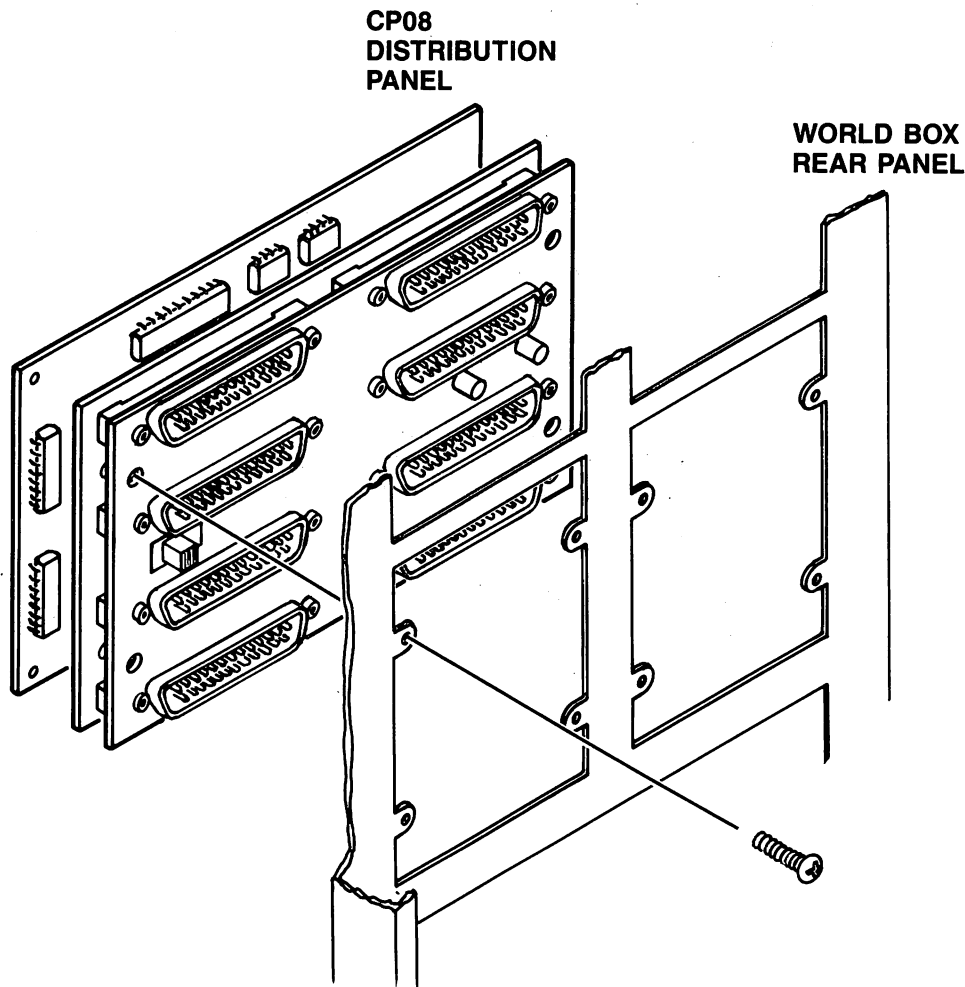

CP0801-1239

Figure 3-3. Mounting a CP08/M in a World Box

3.3 Rack-Mounting (Same Cabinet)

There are two ways of mounting the CP08/M for use with rack-mount computers:

- In the rear of a DEC FCC-compatible CPU. It fits in the place of four DEC I/O cutouts.
- In an Emulex rack-mount chassis (which is mounted on the RETMA rails of a 19-inch equipment rack).

In the first case, simply mount the CP08/M in the Emulex rack-mount adapter (see section 1.4 for part number) and then mount the adapter in the DEC I/O cutouts. Run the 64-pin cable that comes with the CS09/E1 from connector J1 on the rear of the CP08/M to connector J1 on the edge of the controller.

If your CPU does not have I/O cutouts, you must mount the CP08/M on the RETMA rails of your equipment rack. In this case, you will need an Emulex rack-mount adapter and a rack-mount chassis (see section 1.4 for part numbers). The following procedure explains how to use these accessories to mount the CP08/M:

1. Place the CP08/M in the rack-mount adapter. See Figure 3-4.
2. Mount the rack-mount adapter (with the CP08/M installed) in one side of the rack-mount chassis. The other side of the rack-mount chassis should contain a blank plate.
3. Mount the entire assembly on the RETMA rails of your equipment rack. Figure 3-5 shows what the completed installation should look like.
4. Attach one end of the 64-pin flat ribbon cable to the **top** connector on the CP08/M (labeled J1) and the other end to the connector on the edge of the CC09 controller, also labeled J1. (Connector J2 is reserved for future expansion).
5. The installation of the distribution panel is now complete. Turn to section 3.4 for instructions on cabling external devices to the distribution panel (terminals, printers, etc.).

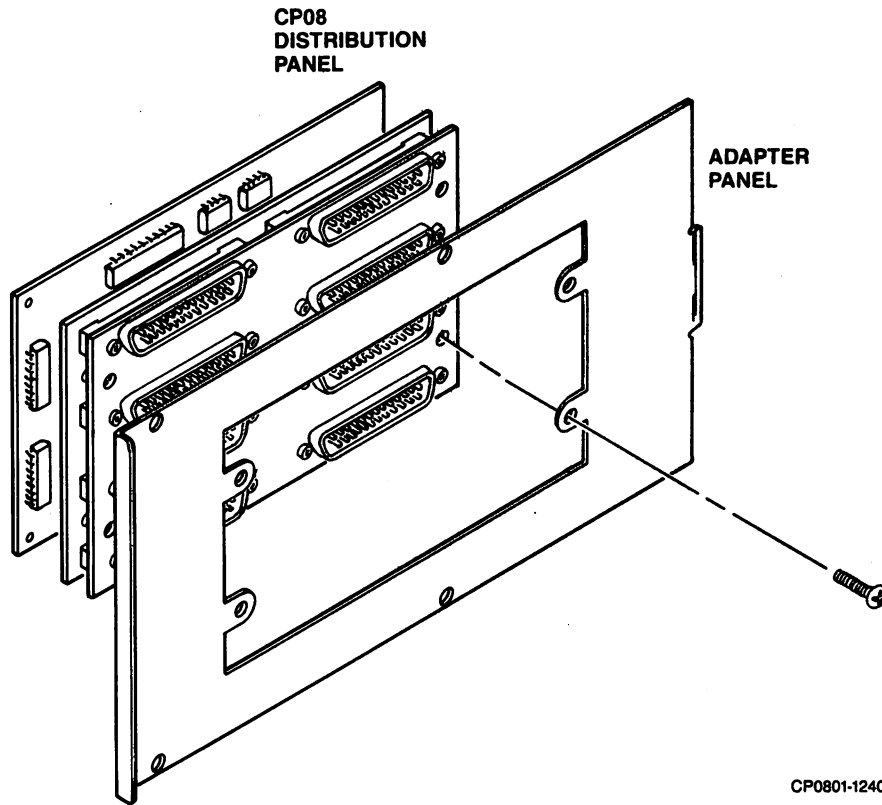

Figure 3-4. Mounting the CP08/M in the Rack-Mount Adapter

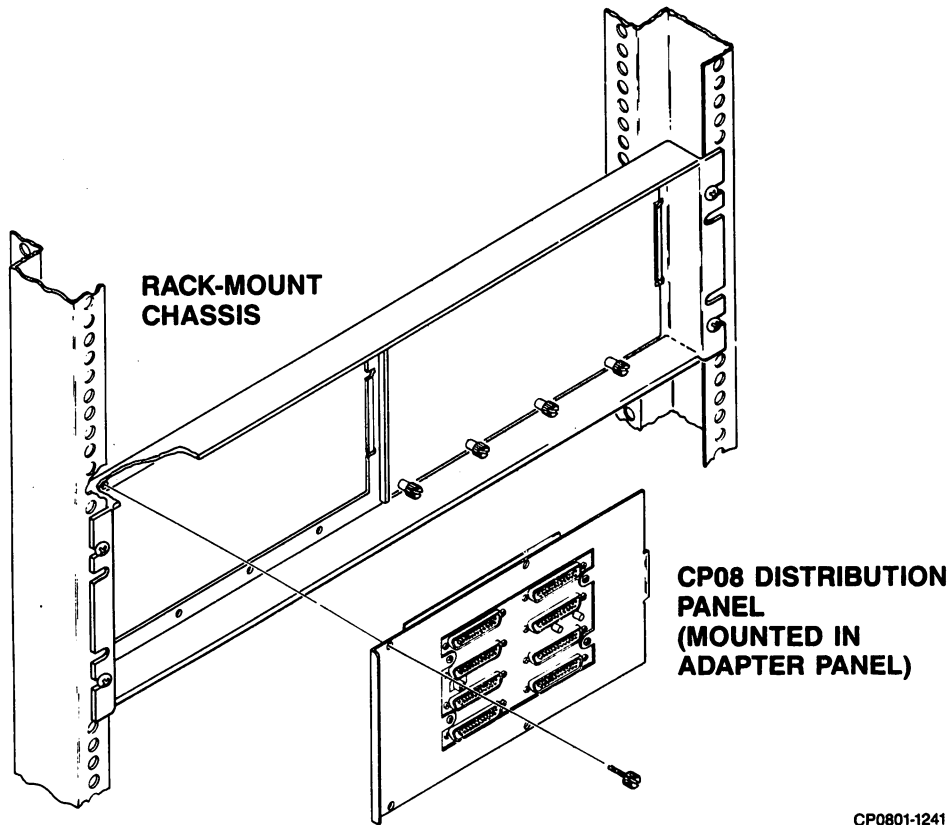

Figure 3-5. Mounting the Rack-Mount Chassis in the Equipment Rack

3.4 Attaching External Devices to The CP08/M Distribution Panel

The following sections describe the types of cables required to connect various user-supplied devices, such as terminals, printers, and modems, to the CP08/M Distribution Panel.

3.4.1 Terminals and Printers

Devices such as terminals and printers which do not require modem control signals for flow control can be connected to a CP08/M port using a simple four-wire cable called a terminal cable. Figure 3-6 shows a schematic of a terminal cable for the CP08/M.

3.4.2 Modems

Modems require cables that can carry the modem control signals. Figure 3-7 shows a diagram of a modem cable.

The CP08/M comes with a modem control board attached to the rear of the panel. This board must remain attached if you are using modem controls.

3.4.3 Null-Modem Operation

The controller module hardware cannot distinguish between ports that are not connected to modems and ports that are. Thus, the host operating system must be configured for modem or modemless operation on a line-by-line basis. If this is impractical because modems are constantly being moved from one line to another, then the host can be configured for modems on all lines. However, in such cases, the four-wire cable described for local devices will not work, because the software will expect to receive modem control signals and will not transmit data until the proper signals are received.

Nearly all terminals keep DTR and RTS asserted at all times, and a null-modem cable uses these constant signals to drive various inputs on the CP08/M. This gives the illusion that a modem has generated these signals, so the software can transmit at any time. Figure 3-8 shows a standard null-modem cable for use on channels configured for full-duplex operation. A null-modem cable must be used whenever a device that is normally in the non-modem class is connected to a channel that has been configured for modem operation.

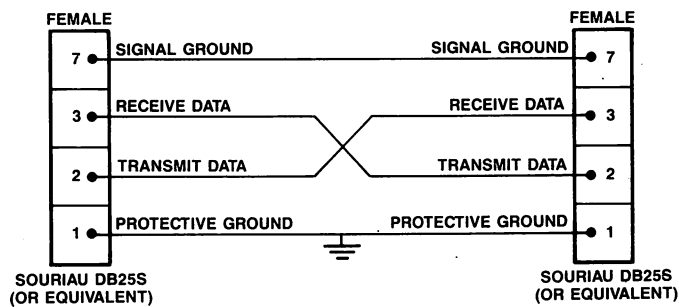

CP0801-0107

Figure 3-6. CP08/M Terminal Cable

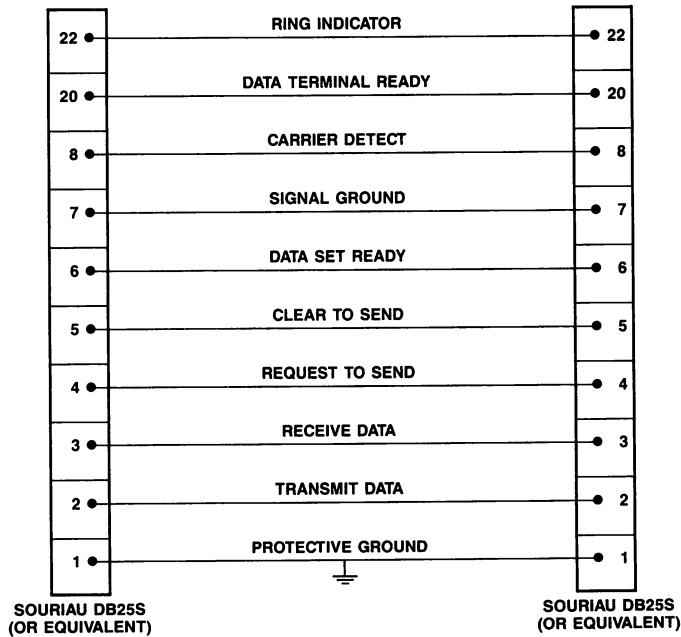

CP0801-0112

Figure 3-7. CP08/M Modem Cable

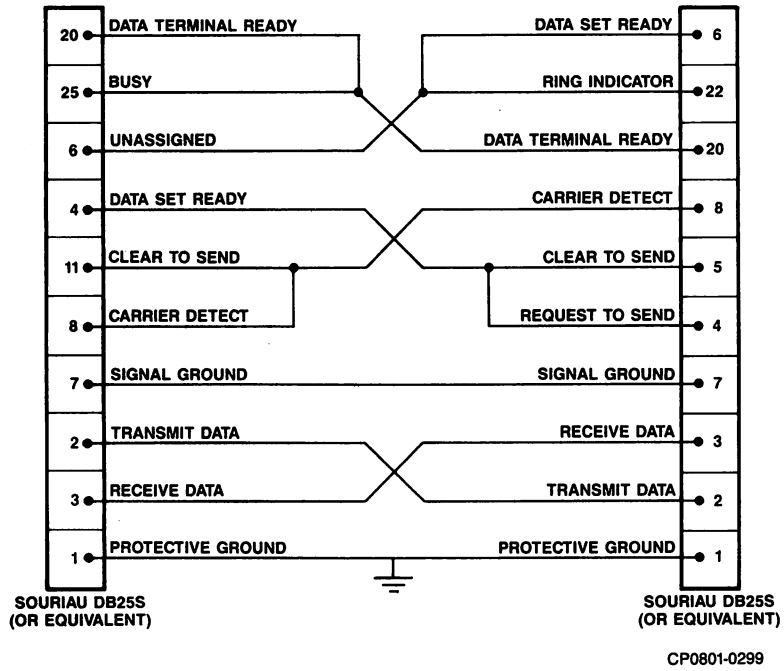

Figure 3-8. CP08/M Null-Modem Cable



Reader's Comments

Your comments and suggestions will help us in our continuous effort to improve the quality and usefulness of our publication.

Manual Part Number _____ Rev. _____

What is your general reaction to this manual? In your judgment is it complete, accurate, well organized, well written, etc.? Is it easy to use? _____

What features are most useful? _____

What faults or errors have you found in the manual? _____

Does this manual satisfy the need you think it was intended to satisfy? _____

Does it satisfy *your* needs? _____ Why? _____

Please send me the current copy of the *Controller Handbook*, which contains the information on the remainder of EMULEX's controller products.

Name _____

Street _____

Title _____

City _____

Company _____

State/Country _____

Department _____

Zip _____

Additional copies of this document are available from:

Emulex Corporation
3545 Harbor Boulevard
P.O. Box 6725
Costa Mesa, CA 92626
Attention: Customer Services

Fold Here and Staple

Do Not Tear — Fold Here



NO POSTAGE
NECESSARY
IF MAILED
IN THE
UNITED STATES

BUSINESS REPLY MAIL

FIRST CLASS PERMIT NO. 202 COSTA MESA, CA

POSTAGE WILL BE PAID BY ADDRESSEE
EMULEX CORPORATION
3545 HARBOR BOULEVARD
P.O. BOX 6725
COSTA MESA, CALIFORNIA 92626
ATTN: TECHNICAL PUBLICATIONS

